

A Half-second Microgravity Instructor's Manual



December 2012

Kibo-ABC

Contents

1.0 Introduction	1
2.0 Examples of Microgravity Phenomena under the Simple Free-Fall	2
2.1 Candle flame	2
2.2 Two Rubber balloons	2
2.3 Diamagnetic levitation	3
2.4 Collision of water drops	3
2.5 Air bubbles in water	4
3.0 Fabrication of Simple Free-Fall Apparatus	5
3.1 Drop box	5
3.2 Clutch and release mechanism	6
3.3 Camera	7
3.4 Supporting Structure	8
3.5 Cushion	10
3.6 Hoist	10
4.0 Tips for Obtaining Better Results	11
4.1 Camera installation	11
4.2 Mitigating disturbances by g-jitter	11
Disclaimer	12

1.0 Introduction

Constant microgravity condition is one of the most unique and useful features of the space environment provided on board the International Space Station. Although the microgravity, or zero-gravity, in space is widely known through the activities of astronauts today, general understanding to microgravity is not very accurate, because it is hard to be experienced. Thus, it will be very effective to show some typical phenomena under microgravity by utilizing a simple free-fall method, and have the people witness the occurrences.

A simple free-fall method was first applied to serious research purposes by Seiichiro Kumagai of the University of Tokyo in 1950s. The purpose of his experiment was to scrutinize the burning process of fuel mist particles for better efficiency of internal combustion engines. Theoretically the burning processes of larger droplets and fine mist particles are indistinguishable. While it is technically easier to observe larger ones, holding a large droplet is difficult. In addition the flame is deformed by buoyancy convection. The solution of these problems was to remove the gravitation from the system. Kumagai utilized a simple free-fall system with a portable clay cooking stove fitted with a Nikon motor drive camera, newly developed at that time and capable of 250 frames a second shooting, dropped from the ceiling to the floor. This pioneering microgravity experiment opened a new realm for investigation of the fundamental nature of combustion, as well as microgravity sciences in general.

Today, there are large-scale free-fall facilities for microgravity research in some countries. Short-time microgravity condition can be achieved by parabolic maneuver of an aircraft. Simple half a second free-fall, however, is still useful for education and outreach purposes to facilitate the understanding of the importance of microgravity sciences and space development activities.

Not only students and general public can acquire knowledge from the simple free-fall, but also performers of the demonstration can learn a great deal from the activity. Thus, researchers or engineers in the field of space environment utilization are recommended to perform this simple free-fall demonstration as a part of outreach activity, irrespective to one's own specialty. Since we all live under the constant gravity and usually do not care about it, even an experienced space engineer could be surprised by unexpected finding

2.0 Examples of Microgravity Phenomena under the Simple Free-Fall

2.1 Candle flame

Candle flame is one of the most impressive and easy-to-observe subject under microgravity. The flame shrinks right after the beginning of the fall. This is due to the suppression of buoyancy convection around the flame under microgravity. But the rest of air in the drop box, however, is still moving by inertia. The flame is buffeted by the residual air flow. The gradual return of gravity due to aerodynamic drag also causes disturbance.



2.2 Two Rubber balloons

Put two rubber balloons in a box; one is filled with water (right corner) and the other with air (left corner). When the box is falling, the balloon at the right corner goes up while the other at the left corner stays. The water balloon is slightly squashed by the weight of water, or hydrostatic effect. When gravity disappears, the water balloon is restored to its normal near spherical shape.

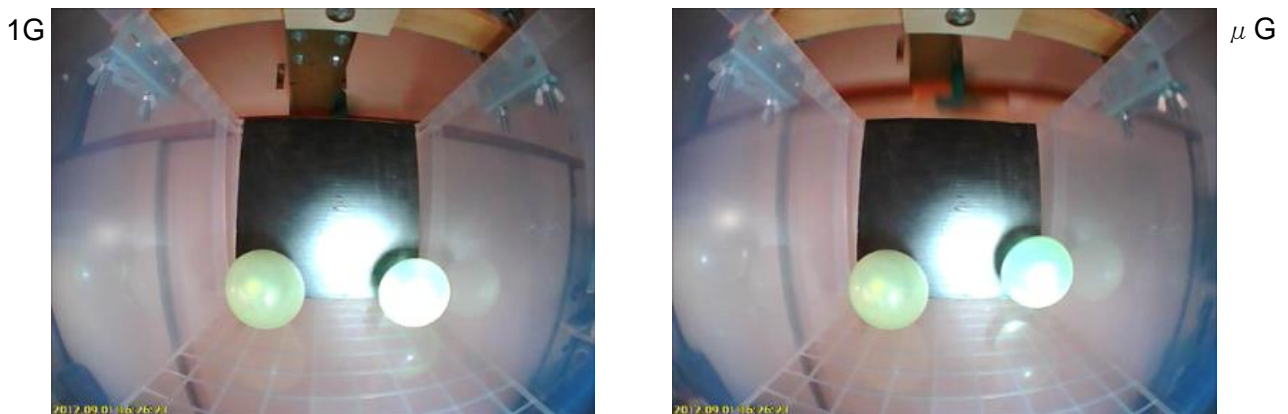

2.3 Diamagnetic levitation

Diamagnetism is the property of any material to create a magnetic field in opposition to an externally applied magnetic field. The contribution of the diamagnetism is usually negligibly small and hard to be observed.

Place a small neodymium magnet with 6 mm diameter on a 100 gram silver bar (left). During a free-fall, the magnet floats apart from the silver bar (right).



2.4 Collision of water drops

Small amount of water was ejected simultaneously from two nozzles facing each other and collide to form one larger droplet.

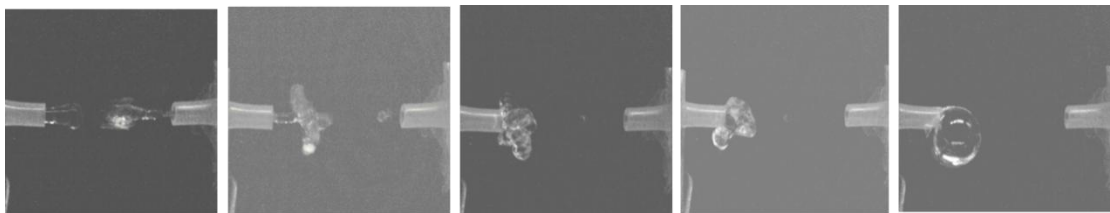

A next photo shows a droplet formation system. The spring is shortened with the weight of a clay lump under normal gravity. When gravity disappears, the spring extends and a droplet is pushed out from the nozzle by the extruded air with the power of spring.

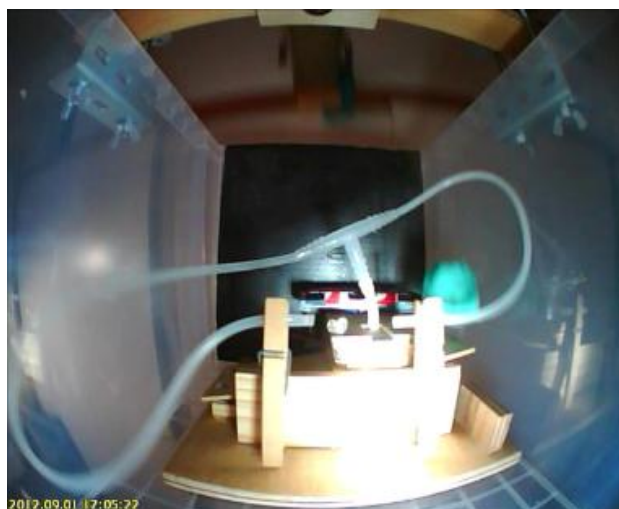

2.5 Air bubbles in water

Air bubbles generated in a small jar by air pump continues to come up to the water surface under normal gravity. Under microgravity, bubbles stop rising and become spherical.

1G



μ G



1G

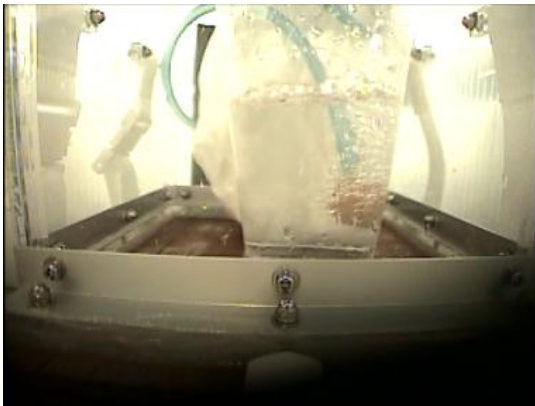

μ G



3.0 Fabrication of Simple Free-Fall Apparatus

A simple free-fall experiment requires just the following materials: a drop box or a capsule, a camera, a clutch and release mechanism, a buffering cushion, and objects to be observed such as a candle.

In addition to the above, a structure to hold the clutch about 2 meters above the floor is required. Utilizing existing commodity such as tall shelves, step ladders or ceiling hooks may be used for this purpose.

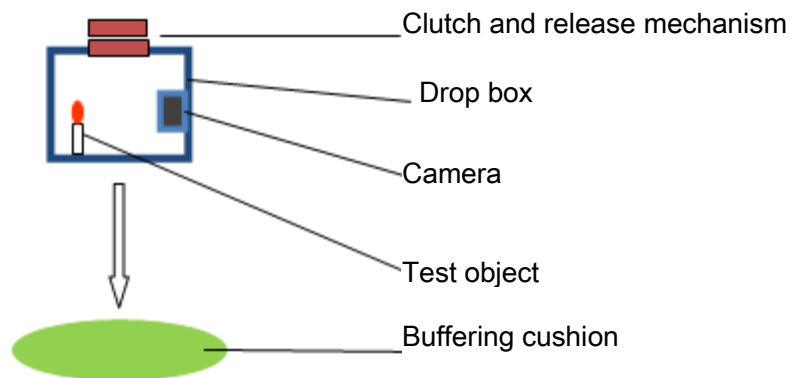

In other cases, using collapsible support structure shown here will be convenient. Although such a little tower structure itself is a kind of the least essential elements of this system as a matter of fact, it may attract much attention and tends to cost some labor to fabricate.

3.1 Drop box

Plastic storage box containers for home use are suitable for this purpose.



3.2 Clutch and release mechanism

The simplest way of free-fall experiment is just to hold and release a drop box by human hands. Another simple method is to cut a string hanging a drop box. Many other mechanical clutch-and-release systems can be made with household parts such as door latches. However, subtle/slight but disturbing swing at the moment of release is inevitable for the most of mechanical systems. To avoid disturbance at the release, electromagnetic systems is thus preferable. Commercially available door magnets which operate with 12 V DC and generate about 500 to 2000 N of holding force with matching armature is one of the best choices.

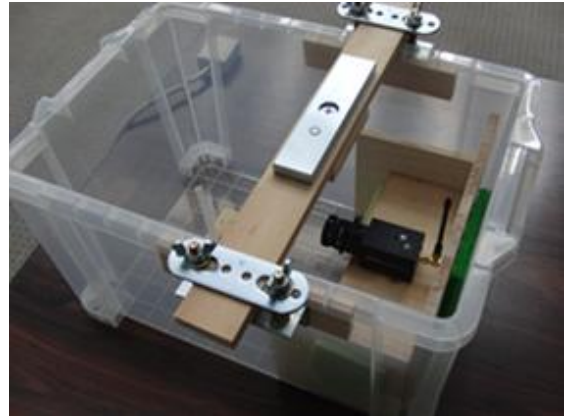
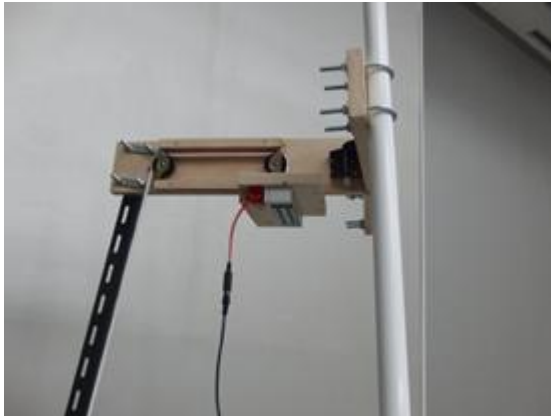

3.3 Camera

Capturing image data is one of the key functions of the system. Drive recorders, or windshield video cameras, may be the easiest choice for this purpose. A drive recorder is a small digital video camera to be attached to the windshield of an automobile to record events on the road. The picture quality tends to be not very good, but it is still acceptable for experiments by younger students. Average models have an accelerometer, or G-sensor, and automatically save video clips right before and after an impact exceeding preset level is detected. Viewing the results is also easy with PC using included software. The only modification needed is to its 12V DC power supply. The power should be supplied with a battery placed in the experiment box, otherwise with the cable from the outside. GPS sensors contained in the camera is unnecessary for the microgravity experiment.

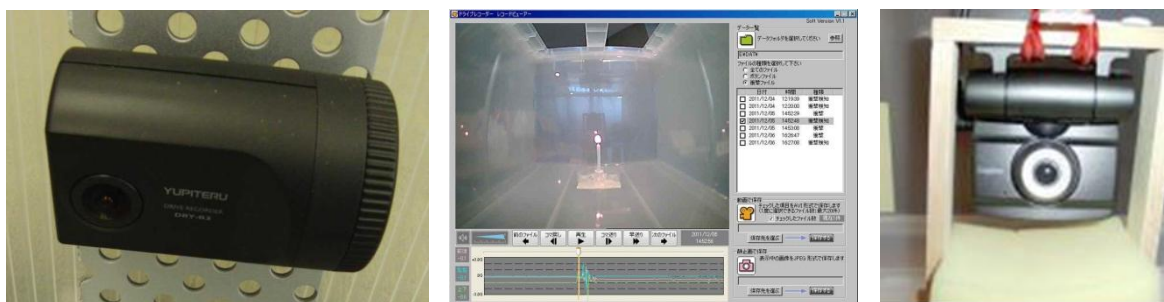

Among the consumer products, Casio High Speed EXILIM(R) series offers practical performance. However, these models are not designated for rough handling; careful protection from landing impact is required.

With Eye-Fi(R) memory cards which can transfer photos and videos wirelessly to Wi-Fi network, it will be easy and efficient for data collection without demounting a camera from the box. In addition, many extra functions of current digital cameras such as image stabilization should be turned off.

Considering the specifications its low prices, USB cameras or web cameras is also suitable. However those are not recommended, since their poor capability to record moving objects.



3.4 Supporting Structure

Small, light-weight, and easy-to-use free-fall apparatus is needed in doing microgravity demonstration for education and outreach purposes. Several types of collapsible support structure have been developed.

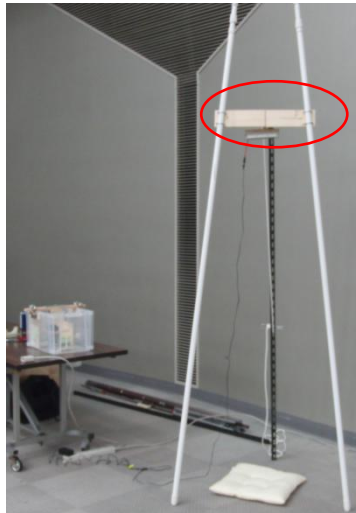

The example shown next page is one of the simplest yet reliable supporting part of the tripod which is shown above pictures circled by a red line. This supporting part is cited from a private website with permission. It is designed to be made with commercially available materials shown pictures under the design drawing.

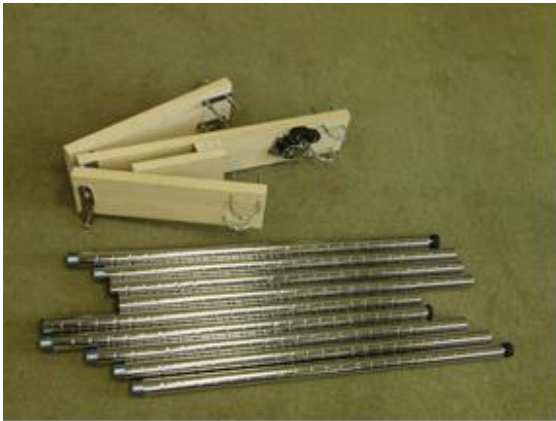
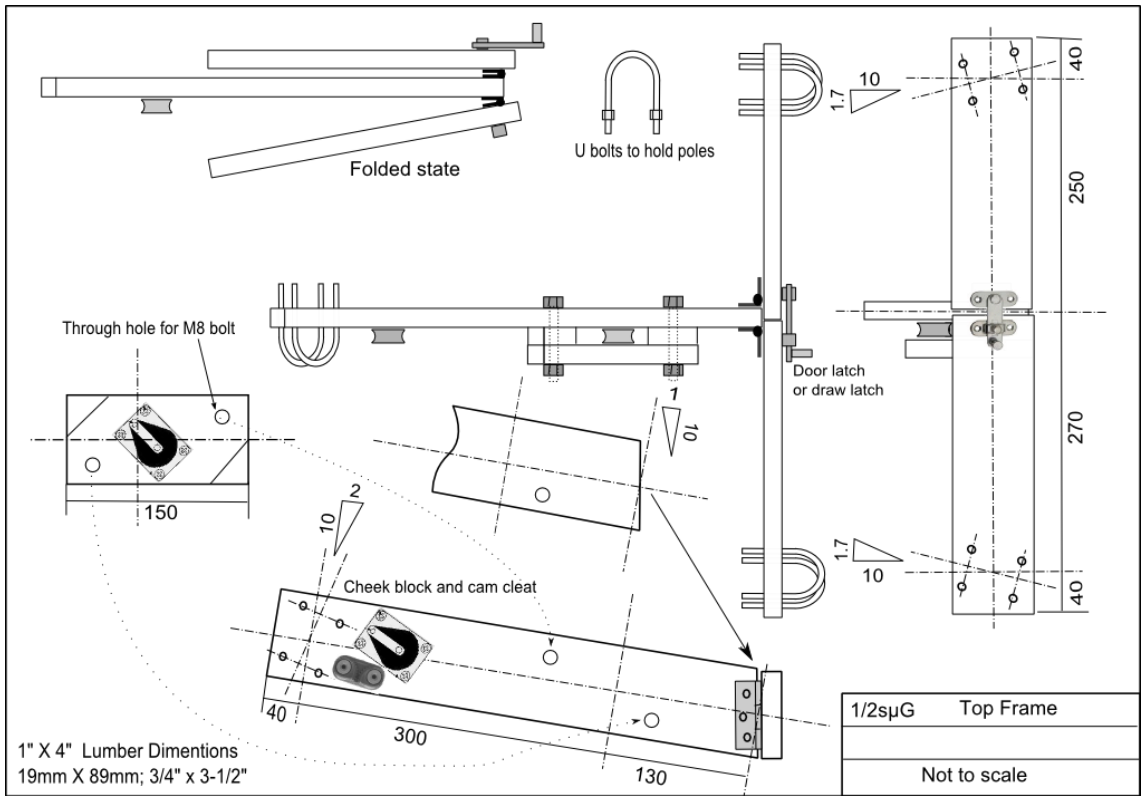

3.5 Cushion

A drop box hits the ground at about the speed of 16 km/h in 1-meter fall. When its drop distance extends to 2 meters, the speed increases to about 22.5 km/h. Choice of an appropriate buffering material is essential to mitigate damages caused by the impact. Highly elastic materials, however, should be avoided because it may cause secondary damages by rebound and subsequent upsetting. Among commercially available materials, cushions or pillows stuffed with polystyrene foam micro beads seems the easiest selection, since they make only minimum rebound.



3.6 Hoist

Hoist is not essential but convenient and fancy. This example utilizes sailboat parts.

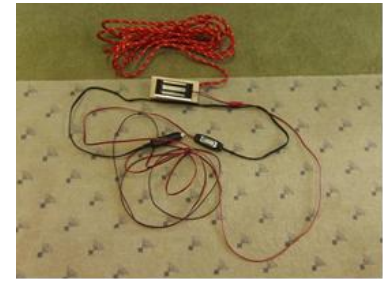

4.0 Tips for Obtaining Better Results

4.1 Camera installation

Drive recorder or windshield video camera can be directly installed inside wall of a drop box since it is designed impact proof. Careful protection from landing impact is required for other standard cameras. An example of friction based shock absorbing camera mount is shown below.

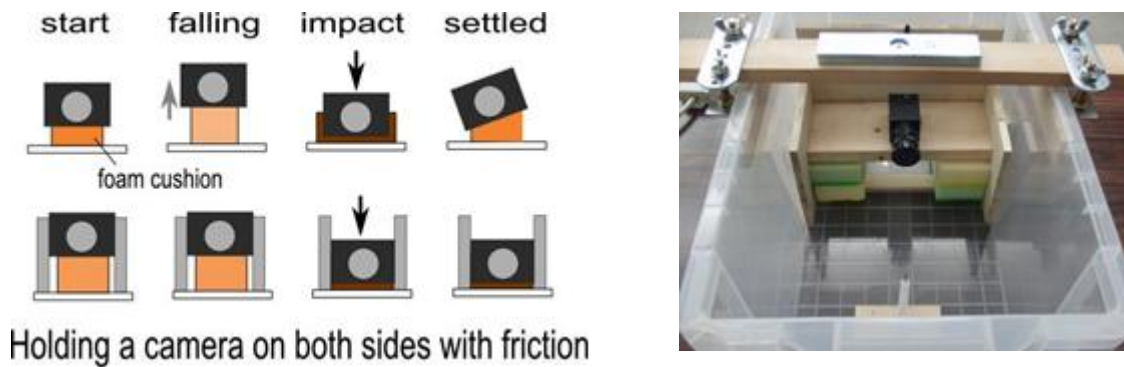

4.2 Mitigating disturbances by g-jitter

In class room physics, every object except materials like a spring is considered as an ideal rigid body. In reality, almost everything is elastic and distorted by the weight of itself. Such distortion is negligible in ordinal daily life, but it often does matter in simple free-fall experiments. Actually, distortion of a drop box and other elements causes vibrations right after it is released and affects the observation.

The figure below shows an example of acceleration profile during a free-fall. Considerable degree of vibration is observed right after release and then it decreases gradually. This vibration is thought to be generated mainly by the mass of the recorder to measure the acceleration and a foam rubber cushion to protect the device.

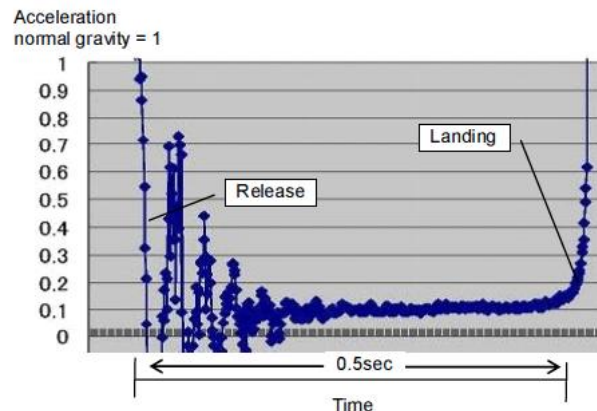

Some of the factors which cause vibration are illustrated in an exaggerated manner below. It is very hard to eliminate all these factors but try to avoid these for better experiment.

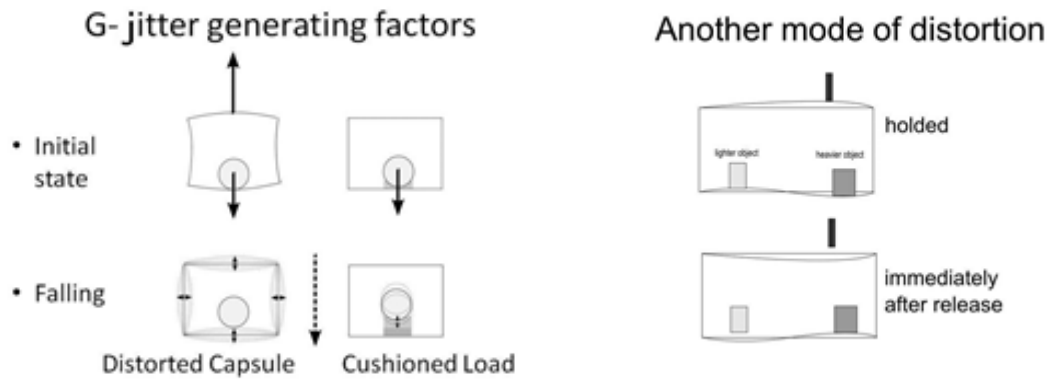

Disclaimer

None of the authors nor other members of Kibo-ABC are responsible to any damage or misconception resulted from the information provided in this document. All users should conduct their operation at their own risk.